

This Page Is Inserted by IFW Operations  
and is not a part of the Official Record

## **BEST AVAILABLE IMAGES**

Defective images within this document are accurate representations of the original documents submitted by the applicant.

Defects in the images may include (but are not limited to):

- BLACK BORDERS
- TEXT CUT OFF AT TOP, BOTTOM OR SIDES
- FADED TEXT
- ILLEGIBLE TEXT
- SKEWED/SLANTED IMAGES
- COLORED PHOTOS
- BLACK OR VERY BLACK AND WHITE DARK PHOTOS
- GRAY SCALE DOCUMENTS

**IMAGES ARE BEST AVAILABLE COPY.**

**As rescanning documents *will not* correct images,  
please do not report the images to the  
Image Problem Mailbox.**



INTERNATIONAL APPLICATION PUBLISHED UNDER THE PATENT COOPERATION TREATY (PCT)

<p>(51) International Patent Classification 6 : E21B 23/00</p>	<p>A1</p>	<p>(11) International Publication Number: WO 99/04135 (43) International Publication Date: 28 January 1999 (28.01.99)</p>
<p>(21) International Application Number: PCT/US98/04383 (22) International Filing Date: 6 March 1998 (06.03.98) (30) Priority Data: 08/892,709 15 July 1997 (15.07.97) US (71) Applicant: MARATHON OIL COMPANY [US/US]; 539 South Main Street, Findlay, OH 45840 (US). (72) Inventor: COLLINS, Gary, J.; 2211 Landscape Way, Richmond, TX 77469 (US). (74) Agents: HUMMEL, Jack, L. et al.; Marathon Oil Company, P.O. Box 269, Littleton, CO 80160-0269 (US).</p>		<p>(81) Designated States: AL, AM, AT, AU, AZ, BA, BB, BG, BR, BY, CA, CH, CN, CU, CZ, DE, DK, EE, ES, FI, GB, GE, GH, GM, GW, HU, ID, IL, IS, JP, KE, KG, KP, KR, KZ, LC, LK, LR, LS, LT, LU, LV, MD, MG, MK, MN, MW, MX, NO, NZ, PL, PT, RO, RU, SD, SE, SG, SI, SK, SL, TJ, TM, TR, TT, UA, UG, UZ, VN, YU, ZW, ARIPO patent (GH, GM, KE, LS, MW, SD, SZ, UG, ZW), Eurasian patent (AM, AZ, BY, KG, KZ, MD, RU, TJ, TM), European patent (AT, BE, CH, DE, DK, ES, FI, FR, GB, GR, IE, IT, LU, MC, NL, PT, SE), OAPI patent (BF, BJ, CF, CG, CI, CM, GA, GN, ML, MR, NE, SN, TD, TG).</p> <p>Published With international search report.</p>

(54) Title: DEFORMED MULTIPLE WELL TEMPLATE AND PROCESS OF USE

(57) Abstract

A deformed multiple well template (10, 110, 210) and a process for positioning the deformed template (10, 110, 210) downhole, expanding the template and drilling at least one subterranean well bore via said template (10, 110, 210). The template (10, 110, 210) has at least a portion thereof deformed and may be symmetrical or asymmetrical as deformed and/or expanded.

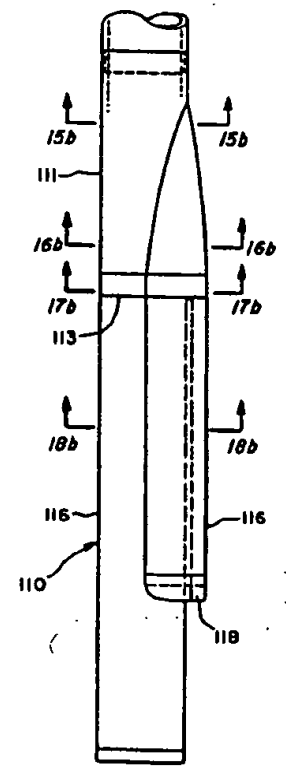

**FOR THE PURPOSES OF INFORMATION ONLY**

Codes used to identify States party to the PCT on the front pages of pamphlets publishing international applications under the PCT.

AL	Albania	ES	Spain	LS	Lesotho	SI	Slovenia
AM	Armenia	FI	Finland	LT	Lithuania	SK	Slovakia
AT	Austria	FR	France	LU	Luxembourg	SN	Senegal
AU	Australia	GA	Gabon	LV	Latvia	SZ	Swaziland
AZ	Azerbaijan	GB	United Kingdom	MC	Monaco	TD	Chad
BA	Bosnia and Herzegovina	GE	Georgia	MD	Republic of Moldova	TG	Togo
BB	Barbados	GH	Ghana	MG	Madagascar	TJ	Tajikistan
BE	Belgium	GN	Guinea	MK	The former Yugoslav Republic of Macedonia	TM	Turkmenistan
BF	Burkina Faso	GR	Greece	ML	Mali	TR	Turkey
BG	Bulgaria	HU	Hungary	MN	Mongolia	TT	Trinidad and Tobago
BJ	Benin	IE	Ireland	MR	Mauritania	UA	Ukraine
BR	Brazil	IL	Israel	MW	Malawi	UG	Uganda
BY	Belarus	IS	Iceland	MX	Mexico	US	United States of America
CA	Canada	IT	Italy	NE	Niger	UZ	Uzbekistan
CF	Central African Republic	JP	Japan	NL	Netherlands	VN	Viet Nam
CG	Congo	KE	Kenya	NO	Norway	YU	Yugoslavia
CH	Switzerland	KG	Kyrgyzstan	NZ	New Zealand	ZW	Zimbabwe
CI	Côte d'Ivoire	KP	Democratic People's Republic of Korea	PL	Poland		
CM	Cameroon	KR	Republic of Korea	PT	Portugal		
CN	China	KZ	Kazakistan	RO	Romania		
CU	Cuba	LC	Saint Lucia	RU	Russian Federation		
CZ	Czech Republic	LI	Lichtenstein	SD	Sudan		
DE	Germany	LK	Sri Lanka	SE	Sweden		
DK	Denmark	LR	Liberia	SG	Singapore		
EE	Estonia						

## DEFORMED MULTIPLE WELL TEMPLATE AND PROCESS OF USE

### CROSS-REFERENCE TO RELATED APPLICATIONS

- 5 This application is a continuation-in-part of copending United States patent application, Serial No. 08/508,635, filed on July 26, 1995 and United States patent application, Serial No. 08/548,565, filed on October 26, 1995.

### BACKGROUND OF THE INVENTION

#### 10 FIELD OF THE INVENTION:

The present invention relates to a multiple well template and process of drilling multiple subterranean wells utilizing the template, and more particularly, to such a template and process wherein the template is deformed, positioned within a subterranean well bore and expanded for use in drilling multiple wells.

#### 15 DESCRIPTION OF RELATED ART:

Increasingly, well bores are being drilled into subterranean formations at an orientation which is purposely deviated from true vertical by means of conventional whipstock technology or a mud motor secured in the drill string adjacent the drill bit. In fractured subterranean formations, deviated wells are  
20 utilized to increase the area of drainage defined by the well within the subterranean formation, and thus, increase production of hydrocarbons from the subterranean formation. An inherent problem in utilizing a conventional whipstock to drill a deviated well is that both the depth and radial orientation of the whipstock is set when the whipstock is positioned in the well bore and cannot  
25 be changed without retrieving the whipstock from the well bore and changing the depth and/or radial orientation thereof.

In addition, wells drilled from offshore drilling platforms are usually deviated to increase the number of wells which can be drilled and completed from a single platform. Offshore drilling platforms which are utilized in deep  
30 water to drill and complete wells in a subterranean formation vary in size, structure, and cost depending upon the water depth and the loads in which the platform will be set. For example, a platform may be constructed to be supported in part by one leg or caisson which extends to the ocean floor or by

as many as eight such legs or caissons. Costs of such offshore drilling platforms vary from approximately \$5,000,000 to \$500,000,000. Each offshore drilling platform is equipped with a set number of slots via which deviated wells can be drilled and completed through surface casing which is secured at the mudline by  
5 conventional techniques.

Due to the significant capital expenditure required for these offshore platforms, templates and processes for drilling and completing multiple wells via a single conductor, surface or intermediate casing have been developed. Although the templates which have been developed can be utilized to drill and  
10 complete wells into subterranean formations or zones of the same or varying depths, these templates are not designed to drill and complete conventional sized bores, e.g. 7 inches, from a well bore of a similar conventional size so as to maximize the production rate of fluid from the subterranean formation(s) and/or zone(s) and provide mechanical integrity and a hydraulic seal at the  
15 template. Thus, a need exists for apparatus and processes to drill and complete multiple subterranean wells of a conventional size from a well bore of a similar conventional size into a plurality of subterranean formations or zones. A further need exists for an apparatus and process to drill and complete multiple subterranean well bores at greater degrees of separation from each other  
20 thereby significantly increasing the area of drainage and thus enhancing hydrocarbon recovery from the well.

Accordingly, it is an object of the present invention to provide a deformed template and process for drilling and completing multiple subterranean wells having bore sizes which substantially correspond to the size of the bore from  
25 which the multiple wells are being drilled utilizing such template.

It is another object of the present invention to provide a process for expanding a multi well deformed template in situ.

It is a further object of the present invention to provide a deformed template and process for drilling and completing multiple wells from an already  
30 existing well bore once such template is expanded which is cost effective.

It is still another object of the present invention to provide a deformed template and process for drilling and completing multiple subterranean wells

using such template wherein mechanical integrity and a hydraulic seal at the template are provided.

### SUMMARY OF THE INVENTION

5 To achieve the foregoing and other objects, and in accordance with the purposes of the present invention, as embodied and broadly described herein, one characterization of the present invention may comprise a deformed template for drilling and completing multiple subterranean wells from a first casing. The template comprises a body having at least two tubulars, each of which are  
10 deformed but capable of being expanded upon application of suitable force, and means for securing the body to the first casing.

In another characterization of the present invention, a template is provided for drilling and completing multiple subterranean wells from a first casing. The template comprises a body and means for securing the body to  
15 the first casing. The body has a first end face and a plurality of axially extending bores therethrough which intersect the first end face. At least one of the axially extending bores being deformed for positioning in the first casing and capable of being expanded.

In yet another characterization of the present invention, a process is provided for drilling wells via a first casing which extends from the surface of the earth into a first subterranean well bore. The process comprises securing a  
20 deformed template having at least two tubulars which are deformed to the first casing, expanding each of the at least two tubulars, and drilling a second subterranean well bore through one of the at least two tubulars into a first  
25 subterranean formation.

### BRIEF DESCRIPTION OF THE DRAWINGS

The accompanying drawings, which are incorporated in and form a part of the specification, illustrate the embodiments of the present invention and,  
30 together with the description, serve to explain the principles of the invention.

In the drawings:

FIG. 1 is a cross sectional view of one embodiment of a template of the present invention in an expanded form;

FIG. 2 is a cross sectional view of the embodiment of the template of the present invention of FIG. 1 in a deformed state for positioning in a subterranean well bore;

FIG. 3a is a sectional view of one embodiment of the template of the present invention taken along the line 3a-3a of Figure 1;

FIG. 3b is a sectional view of one embodiment of the template of the present invention taken along the line 3b-3b of Figure 2;

FIG. 4a is a sectional view of one embodiment of the template of the present invention taken along the line 4a-4a of Figure 1;

FIG. 4b is a sectional view of one embodiment of the template of the present invention taken along the line 4b-4b of Figure 2;

FIG. 5a is a sectional view of another embodiment of the body of the template of the present invention in an expanded state;

FIG. 5b is a sectional view of another embodiment of the body of the template of the present invention in a deformed state;

FIG. 6a is a sectional view of a further embodiment of the body of the template of the present invention in an expanded state;

FIG. 6b is a sectional view of further embodiment of the body of the template of the present invention in a deformed state;

FIG. 7a is a sectional view of a still another embodiment of the body of the template of the present invention in an expanded state;

FIG. 7b is a sectional view of still another embodiment of the body of the template of the present invention in a deformed state;

FIG. 8 is a cross sectional view of another embodiment of a template of the present invention in an expanded form;

FIG. 9 is a cross sectional view of the embodiment of the template of the present invention of FIG. 8 in a deformed state for positioning in a subterranean well bore;

FIG. 10a is a sectional view of another embodiment of the template of the present invention taken along the line 10a-10a of Figure 8;

FIG. 10b is a sectional view of another embodiment of the template of the present invention taken along the line 10b-10b of Figure 9;

FIG. 11a is a sectional view of another embodiment of the template of the present invention taken along the line 11a-11a of Figure 8;

5 FIG. 11b is a sectional view of another embodiment of the template of the present invention taken along the line 11b-11b of Figure 9;

FIGS. 12a-12g are schematic views of the downhole template of the present invention which is illustrated in FIGS. 8 and 9 as utilized to drill and complete multiple subterranean wells in accordance with the process of the present invention;

10 FIG. 13 is a cross sectional view of still another embodiment of a template of the present invention in an expanded form;

FIG. 14 is a cross sectional view of the embodiment of the template of the present invention of FIG. 13 in a deformed state for positioning in a subterranean well bore;

15 FIG. 15a is a sectional view of the embodiment of the template of the present invention taken along the line 15a-15a of Figure 13;

FIG. 15b is a perspective view of the embodiment of the template of the present invention taken along the line 15b-15b of Figure 14;

20 FIG. 16a is a sectional view of the embodiment of the template of the present invention taken along the line 16a-16a of Figure 13;

FIG. 16b is a sectional view of the embodiment of the template of the present invention taken along the line 16b-16b of Figure 14;

25 FIG. 17a is a sectional view of the embodiment of the template of the present invention taken along the line 17a-17a of Figure 13;

FIG. 17b is a sectional view of the embodiment of the template of the present invention taken along the line 17b-17b of Figure 14;

FIG. 18a is a sectional view of the embodiment of the template of the present invention taken along the line 18a-18a of Figure 13;

30 FIG. 18b is a sectional view of the embodiment of the template of the present invention taken along the line 18b-18b of Figure 14;



FIG. 19 is a cross sectional view of a further embodiment of a template of the present invention in an expanded form;

FIG. 20 is a cross sectional view of the embodiment of the template of the present invention of FIG. 19 in a deformed state for positioning in a subterranean well bore;

FIG. 21a is a sectional view of the embodiment of the template of the present invention taken along the line 21a-21a of Figure 19;

FIG. 21b is a sectional view of the embodiment of the template of the present invention taken along the line 21b-21b of Figure 20;

FIG. 22a is a sectional view of the embodiment of the template of the present invention taken along the line 22a-22a of Figure 19;

FIG. 22b is a sectional view of the embodiment of the template of the present invention taken along the line 22b-22b of Figure 20;

FIG. 23a is a sectional view of the embodiment of the template of the present invention taken along the line 23a-23a of Figure 19;

FIG. 23b is a sectional view of the embodiment of the template of the present invention taken along the line 23b-23b of Figure 20;

FIG. 24a is a sectional view of the embodiment of the template of the present invention taken along the line 24a-24a of Figure 19;

FIG. 24b is a sectional view of the embodiment of the template of the present invention taken along the line 24b-24b of Figure 20;

FIG. 25a is a sectional view of an alternative embodiment of the template of the present invention taken along the line 21a-21a of Figure 19;

FIG. 25b is a sectional view of an alternative embodiment of the template of the present invention taken along the line 21b-21b of Figure 20;

FIG. 26a is a sectional view of an alternative embodiment of the template of the present invention taken along the line 22a-22a of Figure 19;

FIG. 26b is a sectional view of an alternative embodiment of the template of the present invention taken along the line 22b-22b of Figure 20;

FIG. 27a is a sectional view of an alternative embodiment of the template of the present invention taken along the line 23a-23a of Figure 19;

FIG. 27b is a sectional view of an alternative embodiment of the template of the present invention taken along the line 23b-23b of Figure 20;

FIG. 28a is a sectional view of an alternative embodiment of the template of the present invention taken along the line 24a-24a of Figure 19; and

5 FIG. 28b is a sectional view of an alternative embodiment of the template of the present invention taken along the line 24b-24b of Figure 20.

#### DETAILED DESCRIPTION OF THE PREFERRED EMBODIMENTS

10 Referring to FIG. 1, a multiple well template or guide is illustrated generally as 10 and has a generally tubular upper section 11, an intermediate body section 13, and a plurality of tubular members 16. Body section 13 is provided with two bores 14 and 15 therethrough. As secured together with the upper section bores 14 and 15 communicate with bore 12 through tubular upper section 11 thereby defining a generally Y-shaped junction having one inlet, i.e. 15 bore 12, and two outlets, i.e. bores 14 and 15. The upper end of body 13 defines an upper end face 19 which both bores 14 and 15 intersect. One or more tubular members 16 are secured together, aligned with bore 14 or 15 and secured to body section 13. In a like manner, one or more tubular members 16 are secured to the other bore 14 or 15. The components of the multiple well 20 template or guide of FIG. 1 may be secured together by any suitable means as will be evident to a skilled artisan, such as by welds. One set of tubular members 16 are provided with screw threads 17 at the lower end thereof for attachment to a suitable float valve (not illustrated) while the other set of tubular members 16 are provided with a bull plug or welded cap 18. Although the 25 tubulars 16 which are aligned with each bore 14 and 15 are generally parallel, the tubulars may be arranged so as to diverge from each other toward the bottom of the template as arranged in a well bore. If arranged to diverge, the degree of such divergence usually should not exceed 2° over the entire length of template 10, and is preferably less than 1°. In the embodiment illustrated in 30 FIGS. 1 and 2, one set of tubular members 16 is shorter than the other set so as to provide a portion of subterranean formation between the ends of each set of

tubular members within which a drill string emanating from the shorter set may be deviated so as to minimize the possibility of interference between well bores which are drilled and completed in accordance with the present invention. The sets of tubular members may also be substantially identical in length. In either  
5 embodiment, one or both sets of tubular members 16 may be provided with a whipstock(s) secured thereto to further assist in minimizing interference between the well bores drilled utilizing template 10 of the present invention.

The embodiment of the multiwell template illustrated in FIG. 1 and described above is crushed or deformed (FIG. 2) to permit passage through a  
10 subterranean well bore. As illustrated in FIG. 2, the multiwell template 10 of FIG. 2 has one side thereof, i.e. one side of upper section 11 (FIG. 3b), bore 15 through body section 13 (FIG. 4b) and the tubular members 16 having a bull plug or welded cap 18 secured to the lower end thereof crushed or deformed, while the other side remains in an expanded form. As illustrated in FIGS. 5-7a and b,  
15 the body section of the template of the present invention may have several different shapes or configurations as both constructed and deformed. The template 10 may be crushed by any suitable means, such as by using a mechanical press in conjunction with hydraulic pressure. Template 10 is constructed of metal, for example steel. Template 10 may be utilized at any  
20 point during the construction of a well, and as such, is secured to the bottom of drive pipe, conductor, surface or intermediate casing, or production or intermediate liner by any suitable means, such as welds or screw threads, for positioning in a subterranean well bore as hereafter described. Once positioned at a desired subterranean location, template 10 (FIG. 2) is initially expanded by  
25 means of hydraulic pressure and thereafter fully expanded into the form illustrated in FIG. 1 by means of mechanical swedges and/or casing rollers which may be run on drill pipe to ream the crushed side of template 10 to its original configuration as will be evident to a skilled artisan. The template of the present invention may then be employed to drill and complete multiple subterranean  
30 wells in a manner as hereinafter described. As illustrated in FIG. 1, template 10 is symmetrical as expanded, i.e. bore 12 through first section 11, bores 14 and

15 through body section 13 and the corresponding tubulars 16 depending therefrom are axially symmetrical with respect to the bore through the drive pipe, conductor, surface or intermediate casing, or production or intermediate liner from which template 10 depends.

5 Referring to FIG. 8, another embodiment of the template of the present invention is illustrated generally as 20 and is generally configured as template 10 with generally tubular upper section 21 corresponding to 11, intermediate body section 23 and bores 24 and 25 to 13, 14 and 15, and a plurality of tubular members 26 to 16 of template 10. The upper end of body 23 defines an upper  
10 end face 29 which both bores 24 and 25 intersect. However, bore 25 and the portion of bore 22 through upper tubular 21 and the members 26 aligned with and depending from bore 25 are all axially offset as expanded (FIGS. 8, 10a, and 11a). This axially offset portion of template 20 is deformed or crushed (FIGS. 9, 10b and 11b) for positioning template 20 within a subterranean well  
15 bore as hereafter described.

In operation, a well bore 33 is under reamed by means of an under reamer to form an enlarged section 35 into which template 20 may be subsequently positioned and expanded (FIG. 12a). Template 20 is deformed to the configuration illustrated in FIG. 9 and is secured to the bottom of surface or  
20 intermediate casing 30 by any suitable means, such as welds or screw threads. As illustrated in FIG. 12b, surface or intermediate casing 30 with template 20 secured to the bottom thereof is positioned within a well bore 33 and 35. Well bore 33 can be generally vertical or deviated. Surface or intermediate casing 30 extends to the surface of the earth 31 thereby defining a well head. In  
25 accordance with the present invention, template 20 is expanded (FIG. 12c) by means of hydraulic pressure and a mechanical swedge(s) and/or casing roller(s) to the form illustrated in FIG. 9. Once expanded the template and casing can be cemented in place. A whipstock or orienting cam 37 is sealingly positioned within bore 24 of body section 23 of template 20 and automatically oriented such  
30 as by a lug or key arrangement as will be evident to as skilled so that the

inclination of the whipstock or orienting cam functions to guide a drill string into bore 25.

A conventional drill string 40 including a drill bit and mud motor (FIG. 12d) is transported within casing 30 and into bore 25 of template 20 whereupon plug 28 and cement, if any, is drilled out of tubulars 26. Thereafter, a first well bore 60 is drilled by the drill string in a conventional manner as will be evident to the skilled artisan with drilling mud and formation cuttings being circulated out of well bore 60 to surface 31 and through tubulars 26 and bores 25 and 22 in the template and casing 30 to the surface. Although illustrated in FIG. 12d as deviated, first well bore 60 can also be drilled in a generally vertical orientation. Thereafter, the drill string is withdrawn from casing 30 and liner 62 is lowered through casing 30 and is secured to template 20 (FIG. 12e) by means of conventional liner hanger. The liner hanger may also be seated upon and supported by a profile, e.g. annular shoulder, formed within bore 25 or tubulars 26. The liner hanger includes an expandable packer to seal the annulus between the liner hanger and bore 25 or tubulars 26 and expandable slips to assist in securing the hanger within bore 25 or tubulars 26. Depending upon the total load supported by a profile within bore 25, slips may not be needed to assist in supporting such load. Liner 62 can be cemented within first well bore 60. The whipstock 37 is then withdrawn from bore 24. Since template 20 is asymmetrical as expanded, bore 24 is essentially aligned with casing 30 so that a whipstock or orienting cam is not necessary to divert a drill string therein. In the instance where the template of the present invention is symmetrical as expanded, it will be necessary to rotate and insert the whipstock or orienting cam 37 into bore 25 of template 20. A drill string 40 is then transported via casing 30 into bore 24 and the float equipment which is secured to the lower end of tubulars 26 is drilled out. The drill string is passed through bore 24 and a second well bore 70 is drilled. Although illustrated in FIG. 12f as deviated, second well bore 70 can also be drilled in a generally vertical orientation, usually if first well bore 60 was deviated. Thereafter, the drill string is withdrawn from casing 30 and liner 72 is lowered through casing 30 and is secured to template 20 (FIG. 12g) by means

of conventional liner hanger as described above. Liner 72 can be cemented within second well bore 70 as will be evident to the skilled artisan. The template of the present invention can be utilized during drilling of wells from onshore drilling rigs and/or offshore drilling platforms. As thus completed in accordance with the present invention, fluids, such as hydrocarbons, are simultaneously produced from both wells 60 and 70 via liners 62 and 72, respectively, and commingled for production to the surface via casing 30 or tubing positioned within the casing 30 or separately produced to the surface using dual tubing strings as will be evident to a skilled artisan.

Although the template of the present invention has been described above and illustrated in FIGS. 1-12 as having only one side or portion thereof deformed or crushed, the template may have both sides including tubular members deformed or crushed. In FIG. 13, a multiple well template or guide is illustrated generally as 110 and has a generally tubular upper section 111, an intermediate body section 113, and a plurality of tubular members 116. Body section 113 is provided with two bores 114 and 115 therethrough and has an upper end face 119 which both bores intersect. As secured together with the upper section bores 114 and 115 communicate with bore 112 through tubular upper section 111 thereby defining a generally Y-shaped junction having one inlet, i.e. bore 112, and two outlets, i.e. bores 114 and 115. One or more tubular members 116 are secured together, aligned with bore 114 or 115 and secured to body section 113. In a like manner, one or more tubular members 116 are secured to the other bore 114 or 115. The components of the multiple well template or guide of FIG. 13 may be secured together by any suitable means as will be evident to a skilled artisan, such as by welds or screw threads. One set of tubular members 116 is provided with a float valve (not illustrated) while the other set of tubular members 116 are provided with a bull plug or welded cap 118. If arranged to diverge, the degree of such divergence of the sets of tubular members 116 usually should not exceed  $2^\circ$  over the entire length of template 110, and is preferably less than  $1^\circ$ . In the embodiment illustrated in FIGS. 13 and 14, one set of tubular members 116 is shorter than the other set so as to

provide a portion of subterranean formation between the ends of each set of tubular members within which a drill string emanating from the shorter set may be deviated so as to minimize the possibility of interference between well bores which are drilled and completed in accordance with the present invention. The sets of tubular members may also be substantially identical in length. In either embodiment, one or both sets of tubular members 116 may be provided with a whipstock(s) secured thereto to further assist in minimizing interference between the well bores drilled utilizing template 110 of the present invention.

The embodiment of the multiwell template illustrated in FIG. 13 and described above is crushed or deformed (FIG. 14) to permit passage through a subterranean well bore. As illustrated in FIG. 14, the multiwell template 110 of FIG. 13 has both sides thereof crushed or deformed, i.e. both sides of upper section 111 (FIGS. 15b and 16b), bores 114 and 115 through body section 113 (FIG. 17b) and the tubular members 116 (FIG.18b). As illustrated in FIGS. 5-7a and b, the body section 113 of template 110 of the present invention may have several different shapes or configurations as both constructed and deformed. The template 10 may be crushed by any suitable means, such as by using a mechanical press in conjunction with hydraulic pressure. Template 110 is constructed of metal, for example steel. Template 110 may be utilized at any point during the construction of a well, and as such, is secured to the bottom of drive pipe, conductor, surface or intermediate casing, or production or intermediate liner by any suitable means, such as welds, for positioning in a subterranean well bore as hereafter described. Once positioned at a desired subterranean location, template 110 (FIG. 14) is initially expanded by means of hydraulic pressure and thereafter fully expanded into the form illustrated in FIG. 13 by means of mechanical swedges and/or casing rollers which may be run on drill pipe to ream the crushed side of template 10 to its original configuration as will be evident to a skilled artisan. The template 110 of the present invention may then be employed to drill and complete multiple subterranean wells in a manner as described above and illustrated in FIGS. 12a-g with respect to template 20 (FIGS. 8 and 9). As illustrated in FIG. 14, template 110 is

asymmetrical as expanded, i.e. bore 112 through first section 111, bore 115 through body section 113 and the corresponding tubulars 116 depending therefrom are axially offset with respect to the bore through the drive pipe, conductor, surface or intermediate casing, or production or intermediate liner  
5 from which template 110 depends.

Another embodiment of the multiple well template or guide is illustrated in FIG. 19 generally as 210 and has a generally tubular upper section 211, an intermediate body section 213, and a plurality of tubular members 216. Body section 213 is provided with two bores 214 and 215 therethrough and has an  
10 upper end face 219 which both bores intersect. As secured together with the upper section bores 214 and 215 communicate with bore 212 through tubular upper section 211 thereby defining a generally Y-shaped junction having one inlet, i.e. bore 212, and two outlets, i.e. bores 214 and 215. One or more tubular members 216 are secured together, aligned with bore 214 or 215 and secured  
15 to body section 213. In a like manner, one or more tubular members 216 are secured to the other bore 214 or 215. The components of the multiple well template or guide of FIG. 19 may be secured together by any suitable means as will be evident to a skilled artisan, such as by welds. One set of tubular members 216 is provided with a float valve (not illustrated) while the other set of  
20 tubular members 216 are provided with a bull plug or welded cap 218. If arranged to diverge, the degree of such divergence of the sets of tubular members 216 usually should not exceed  $2^\circ$  over the entire length of template 210, and is preferably less than  $1^\circ$ . In the embodiment illustrated in FIGS. 19 and 20, one set of tubular members 216 is shorter than the other set so as to  
25 provide a portion of subterranean formation between the ends of each set of tubular members within which a drill string emanating from the shorter set may be deviated so as to minimize the possibility of interference between well bores which are drilled and completed in accordance with the present invention. The sets of tubular members may also be substantially identical in length. In either  
30 embodiment, one or both sets of tubular members 216 may be provided with a



whipstock(s) secured thereto to further assist in minimizing interference between the well bores drilled utilizing template 210 of the present invention.

The embodiment of the multiwell template illustrated in FIG. 19 and described above is crushed or deformed (FIG. 20) to permit passage through a  
5 subterranean well bore. As illustrated in FIG. 20, the multiwell template 210 of FIG. 19 has both sides thereof crushed or deformed, i.e. both sides of upper section 211 (FIGS. 21b and 22b), bores 214 and 215 through body section 213 (FIG. 23b) and the tubular members 216 (FIG. 24b). As illustrated in FIGS. 5-7a and b, the body section 213 of template 210 of the present invention may have  
10 several different shapes or configurations as both constructed and deformed. The template 210 may be crushed by any suitable means, such as by using a mechanical press in conjunction with hydraulic pressure. Template 210 is constructed of metal, for example steel. Template 210 may be utilized at any point during the construction of a well, and as such, is secured to the bottom of  
15 drive pipe, conductor, surface or intermediate casing, or production or intermediate liner by any suitable means, such as welds, for positioning in a subterranean well bore as hereafter described. Once positioned at a desired subterranean location, template 210 (FIG. 20) is initially expanded by means of hydraulic pressure and thereafter fully expanded into the form illustrated in FIG.  
20 19 by means of mechanical swedges and/or casing rollers which may be run on drill pipe to ream the crushed side of template 210 to its original configuration as will be evident to a skilled artisan. The template 210 of the present invention may then be employed to drill and complete multiple subterranean wells in a manner as described above and illustrated in FIGS. 12a-g with respect to  
25 template 20 (FIGS. 8 and 9). As illustrated in FIG. 19, template 210 is symmetrical as expanded, i.e. bore 212 through first section 211, bores 214 and 215 through body section 213 and the corresponding tubulars 216 depending therefrom are symmetrical with respect to the bore through the drive pipe,  
conductor, surface or intermediate casing, or production or intermediate liner  
30 from which template 210 depends.

The following example demonstrates the practice and utility of the present invention, but is not to be construed as limiting the scope thereof.

#### EXAMPLE

5 A drilling rig is skidded over a slot on a conventional offshore drilling platform and a 36 inch diameter bore is drilled from mudline to 400 feet. A 30  
inch diameter casing is positioned within the bore and is conventionally  
cemented therein. A drill string with a 26 inch drill bit is inserted within the 30  
inch casing and a 26 inch diameter bore is drilled from 450 feet to a 2500 foot  
10 17 1/2 inch diameter bore is drilled from 2500 feet to 4,500 feet and a 13 3/8 inch  
diameter casing is run to 4,500 feet and cemented. A 12 1/4 inch diameter  
bore is drilled from 4,500 feet to 12,000 feet and the bore is under reamed to  
a 24 inch diameter from 11,940 feet to 12,000 feet. A 9 5/8 inch diameter  
15 casing having one embodiment of the deformed template of the present  
invention secured to the lowermost joint thereof is positioned within the 24 inch  
well bore and the 9 5/8 inch casing is secured to the well head equipment. The  
deformed template is expanded by means of hydraulic pressure and a  
mechanical swedge such that the tubulars thereof are 7 inches in diameter.  
Once expanded the template and 9 5/8 inch diameter casing are cemented in  
20 place. A whipstock or orienting cam is sealingly positioned within one bore of  
body section of the template. A conventional drill string including a drill bit and  
mud motor is transported within the 9 5/8 inch casing and guided by the  
whipstock through one bore of the template to drilled the cement out of tubulars  
of the template. Thereafter, a first well bore is drilled to 15,000 feet by the drill  
25 string in a conventional manner as will be evident to the skilled artisan. The drill  
string is then withdrawn from the 9 5/8 inch casing and a liner is lowered  
through the 9 5/8 inch casing into the first well bore and is secured to the  
template by means of a conventional liner hanger. The liner is cemented within  
the first well bore. The whipstock is then withdrawn from bore of the template  
30 to the surface and the drill string is then transported via the 9 5/8 inch casing  
into the other bore through the template and the float equipment which is

secured to the lower end of tubulars of the template is drilled out. The drill string is passed through this bore and a second well bore is drilled to 16,000 feet. Thereafter, the drill string is withdrawn from the 9 5/8 inch casing and a liner is lowered into the second well bore and is secured to the template by  
5 means of conventional liner hanger. The liner is then cemented within the second well bore.

Although described above as being secured to the bottom of drive pipe, conductor, surface or intermediate casing, or production or intermediate liner by any suitable means, such as welds, the template can be equipped with a  
10 conventional packer assembly (not illustrated) which is positioned about and secured to the periphery of the template, preferably at the upper end thereof as positioned within a well bore. The packer assembly comprises a plurality of expandable, annular elastomeric elements and a plurality of slip elements. In this embodiment, the template is sized to be received within the drive pipe,  
15 conductor, surface or intermediate casing, or production or intermediate liner, and thus, can be lowered by means of a drill string, tubing string, or wireline (not illustrated) within the drive pipe, conductor, surface or intermediate casing, or production or intermediate liner. Once positioned near the lowermost end of drive pipe, conductor, surface or intermediate casing, or production or  
20 intermediate liner, the slips and packer elements are sequentially expanded into engagement with drive pipe, conductor, surface or intermediate casing, or production or intermediate liner in a manner and by conventional means as will be evident to a skilled artisan so as to secure the template within drive pipe, conductor, surface or intermediate casing, or production or intermediate liner  
25 and seal the annulus therebetween. The slips are sized and configured to support not only the template, but also production casings.

Although the multiple well template of the present invention has been illustrated and described as having two bores therethrough, it will be evident to a skilled artisan that the template can be provided with three or more bores  
30 depending upon the diameter of the bore into which the template is positioned and the diameter of the well bores to be drilled using the template.

Although described throughout this description as being separately utilized in the process of the present invention, downhole or subsurface templates 10, 20, 110 or 210 can be secured to at least one tubular of a surface template to drill two or more separate subterranean wells from each of tubular  
5 of a surface template. Additionally, the templates of the present invention may be stacked, for example a template may be secured to the long tubular of another template, or the template of the present invention may be secured to the tubular of a surface template. It is within the scope of the present invention that three or more well bores can be drilled from a common well bore utilizing  
10 separate tubulars of a surface template, in a manner as previously described, and that three or more wells can be drilled and separately completed from each of these well bores by means of the downhole or subsurface multiple well template of the present invention which is secured to each of such tubulars of the surface template.

15 While the foregoing preferred embodiments of the invention have been described and shown, it is understood that the alternatives and modifications, such as those suggested and others, may be made thereto and fall within the scope of the invention.

## CLAIMS

I claim:

- 1           1.     A deformed template for drilling and completing multiple  
2     subterranean wells from a first casing, said template comprising:  
3           a body having at least two tubulars, each of said at least two tubulars  
4     being deformed but capable of being expanded upon application of suitable  
5     force; and  
6           means for securing said body to said first casing.
- 1           2.     The template of claim 1 wherein said at least two tubulars are  
2     deformed substantially symmetrically.
- 1           3.     The template of claim 1 wherein said at least two tubulars are  
2     deformed asymmetrically.
- 1           4.     The template of claim 1 wherein said at least two tubulars are  
2     axially symmetrical when expanded.
- 1           5.     The template of claim 1 wherein said at least two tubulars are  
2     axially asymmetrical when expanded.
- 1           6.     The template of claim 1 wherein said tubulars are divergent.
- 1           7.     The template of claim 1 wherein said body has three tubulars.
- 1           8.     The template of claim 1 wherein one of said at least two tubulars  
2     is longer than the other tubular.
- 1           9.     The template of claim 1 wherein said means for securing  
2     comprises welds.
- 1           10.    The template of claim 1 wherein said means for securing  
2     comprises an packer assembly which is attached around the periphery of said  
3     body.
- 1           11.    The template of claim 1 wherein said first casing is drive pipe,  
2     conductor casing, surface casing, intermediate casing, production liner or  
3     intermediate liner.
- 1           12.    The template of claim 1 wherein said first casing is deviated.
- 1           13.    The template of claim 1 wherein said body is comprised of  
2     multiple components.

1           14. The template of claim 1 wherein said at least two tubulars are  
2 welded together.

1           15. The template of claim 1 further comprising an elongated frame  
2 interposed between and secured to said at least two tubulars.

1           16. The template of claim 1 wherein said body is generally cylindrical.

1           17. The template of claim 1 wherein said body has a one common  
2 inlet in communication with each of said at least two tubulars.

1           18. A template for drilling and completing multiple subterranean wells  
2 from a first casing, said template comprising:

3               a body having a first end face and a plurality of axially extending bores  
4 therethrough which intersect said first end face, at least one of said axially  
5 extending bores being deformed for positioning in said first casing and capable  
6 of being expanded; and

7               means for securing said body to said first casing.

1           19. The template of claim 18 wherein said bores are divergent.

1           20. The template of claim 18 wherein said body has two axially  
2 extending, bores therethrough.

1           21. The template of claim 20 wherein both of said axially extending  
2 bores are deformed.

1           22. The template of claim 20 wherein said two axially extending bores  
2 are divergent.

1           23. The template of claim 20 wherein one of said two bores is longer  
2 than the other bore.

1           24. The template of claim 18 wherein said means for securing  
2 comprises welds.

1           25. The template of claim 18 wherein said means for securing  
2 comprises an packer assembly which is attached around the periphery of said  
3 body.

1           26. The template of claim 18 wherein said first casing is drive pipe,  
2 conductor casing, surface casing, intermediate casing, production liner or  
3 intermediate liner.

- 1           27.    The template of claim 18 wherein said first casing is deviated.
- 1           28.    The template of claim 18 wherein said body has at least three  
2 axially extending bores therethrough.
- 1           29.    The template of claim 18 wherein said body is comprised of  
2 multiple components.
- 1           30.    The template of claim 29 wherein said body comprises a first  
2 section having a bore therethrough, a body section secured to said first section  
3 and having two bores therethrough, at least one first tubular member secured  
4 to said body section, and at least one second tubular member secured to said  
5 body section.
- 1           31.    The template of claim 29 further comprising an elongated frame  
2 interposed between and secured to said first and second tubular members.
- 1           32.    The template of claim 18 wherein said body is generally  
2 cylindrical.
- 1           33.    The template of claim 18 wherein said end face is generally  
2 planar.
- 1           34.    The template of claim 18 wherein said plurality of axially extending  
2 bores have different lengths.
- 1           35.    A process for drilling wells via a first casing which extends from  
2 the surface of the earth into a first subterranean well bore, said process  
3 comprising:  
4                    securing a deformed template having at least two tubulars which  
5 are deformed to said first casing;  
6                    expanding each of said at least two tubulars; and  
7                    drilling a second subterranean well bore through one of said at  
8 least two tubulars into a first subterranean formation.
- 1           36.    The process of claim 35 further comprising;  
2                    enlarging the diameter of said first well bore so as to provide a  
3 subterranean area into which said at least two tubulars can be expanded.

- 1 37. The process of claim 35 further comprising:  
2 securing a first length of production casing to said template, said  
3 first length of production casing extending into said second well bore.
- 1 38. The process of claim 37 further comprising:  
2 producing hydrocarbons from said first subterranean formation  
3 penetrated by said second well bore to said surface of the earth via said first  
4 length of production casing and said first subterranean well bore.
- 1 39. The process of claim 35 further comprising:  
2 drilling a third subterranean well bore through another of said at  
3 least two tubulars.
- 1 40. The process of claim 39 further comprising:  
2 securing a second length of production casing to said template,  
3 said first length of production casing extending into said third well bore.
- 1 41. The process of claim 40 further comprising;  
2 producing hydrocarbons from said second subterranean formation  
3 penetrated by said third well bore to said surface of the earth via said second  
4 length of production casing and said first subterranean well bore.
- 1 42. The process of claim 35 wherein said first casing is drive pipe,  
2 conductor casing, surface casing, intermediate casing, production liner or  
3 intermediate liner.
- 1 43. The process of claim 35 wherein said first casing is deviated.
- 1 44. The process of claim 39 wherein said first, second and third  
2 subterranean well bores have substantially equal diameters.
- 1 45. The process of claim 37 further comprising:  
2 securing a second deformed template to said first length of  
3 production casing.
- 1 46. The process of claim 35 further comprising:  
2 securing a second deformed template to one of said at least two  
3 tubulars.
- 1 47. All inventions described herein.



Fig. 1

Fig. 2

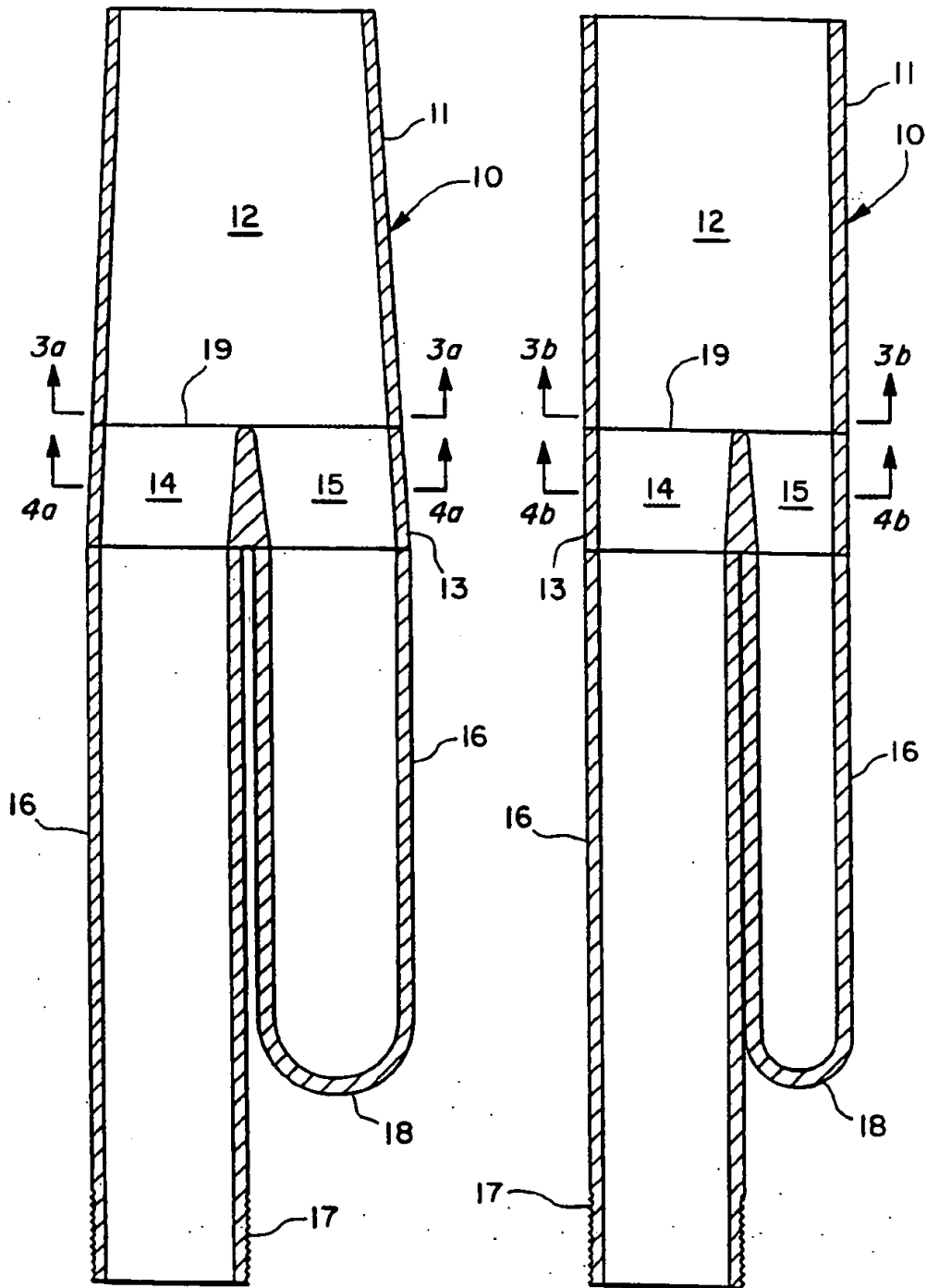

Fig. 3a

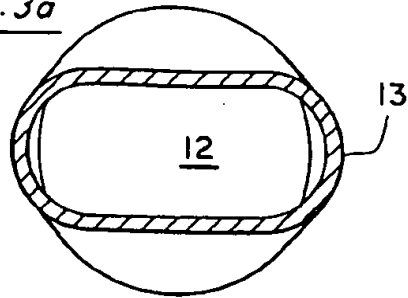

Fig. 3b

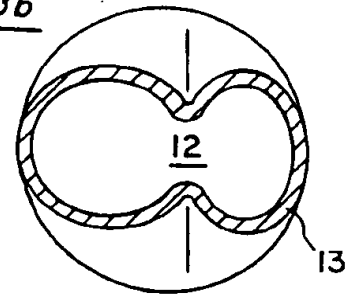

Fig. 4a

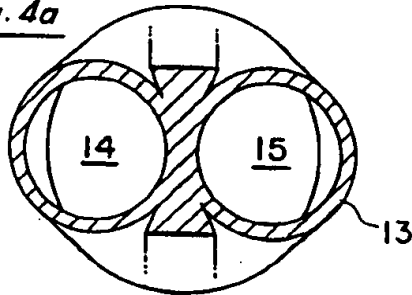

Fig. 4b

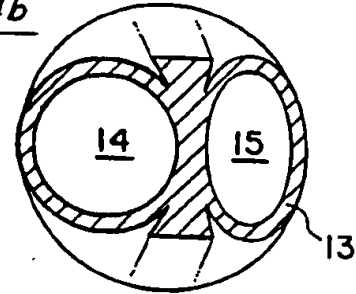

Fig. 5a

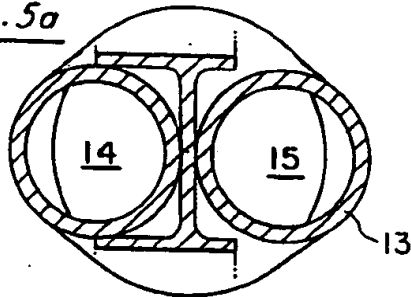

Fig. 5b

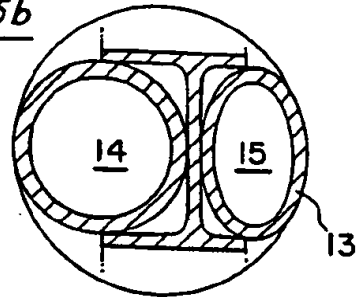

Fig. 6a

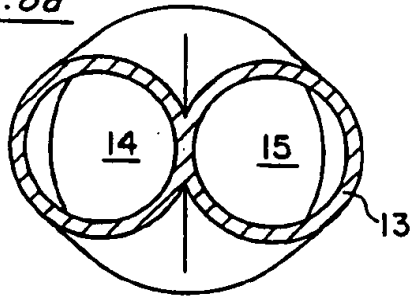

Fig. 6b

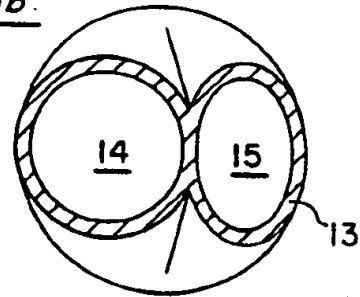

Fig. 7a

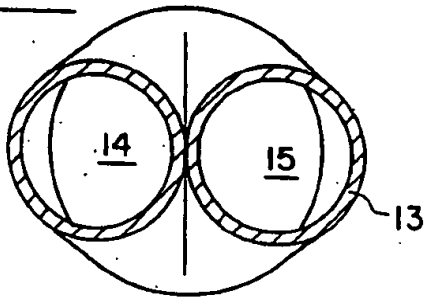

Fig. 7b

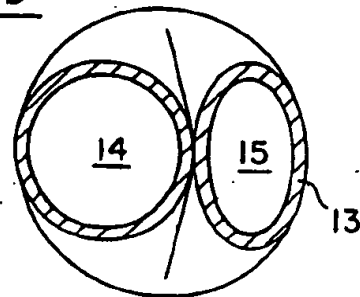

Fig. 8

Fig. 9

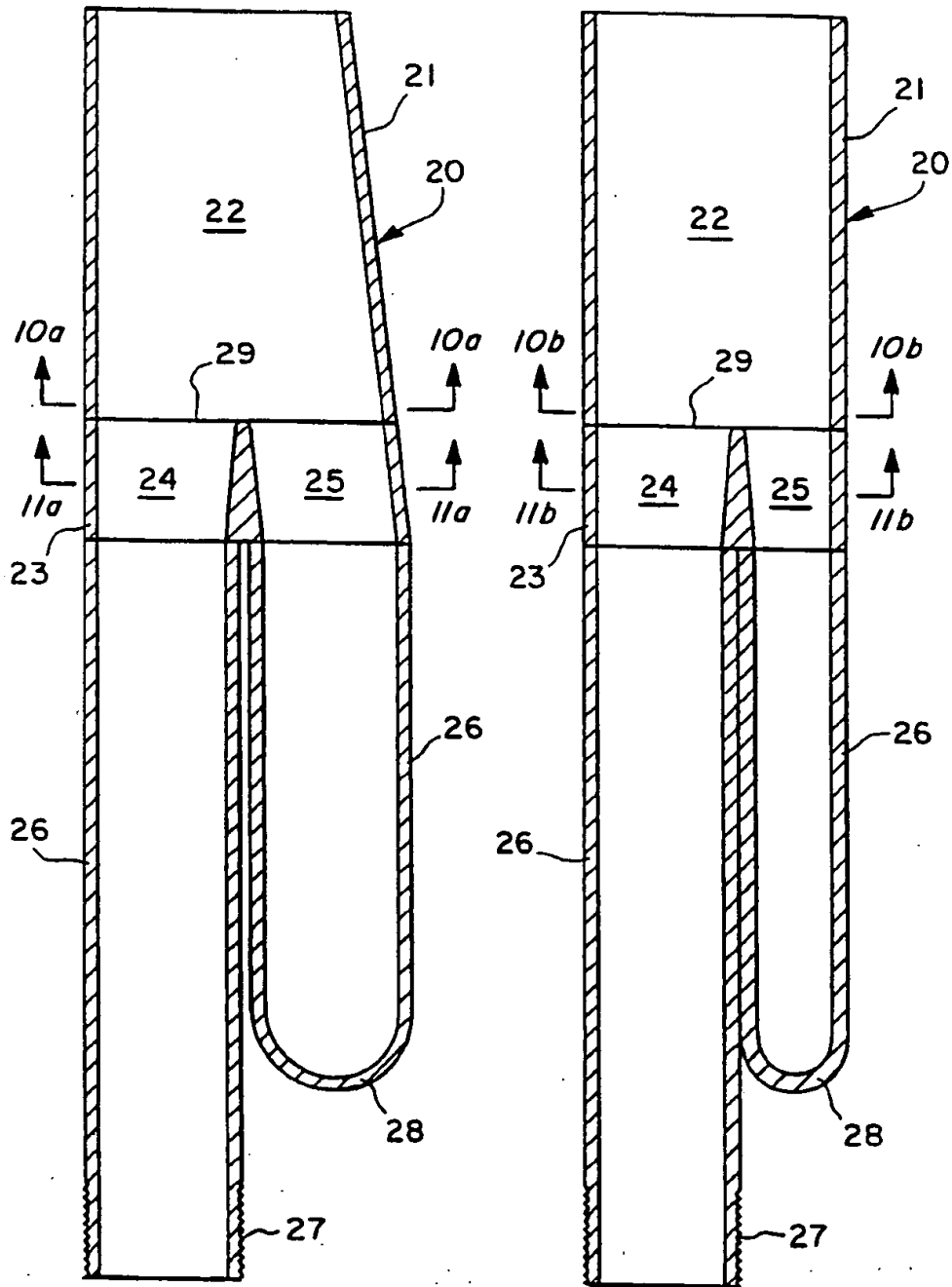

Fig. 10a

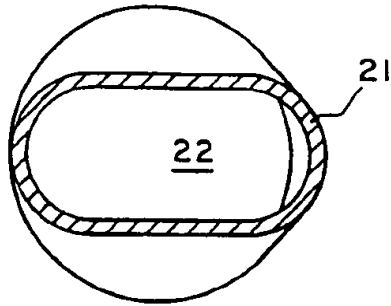

Fig. 10b

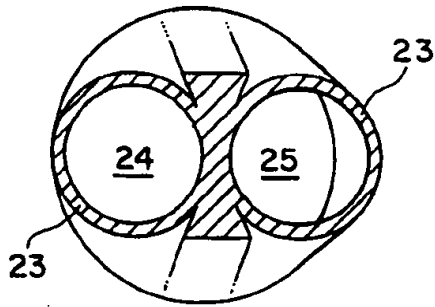
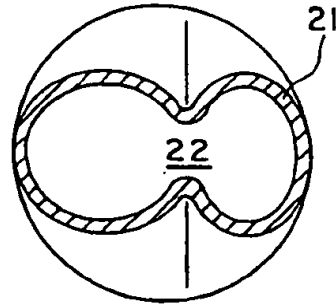

Fig. 11a

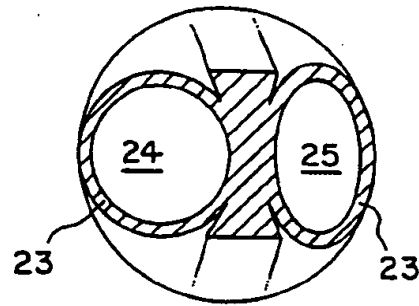

Fig. 11b

Fig. 12b

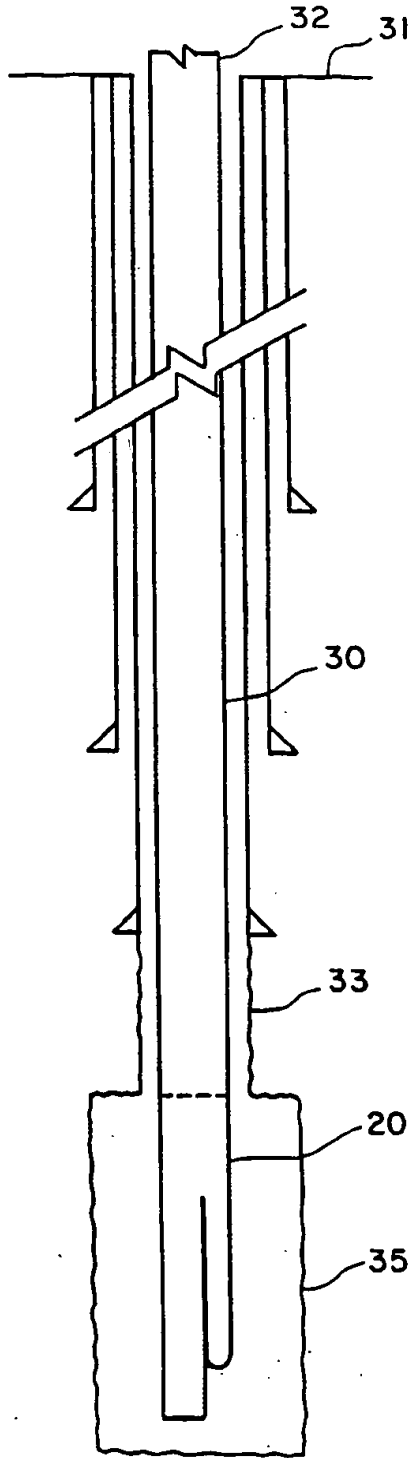
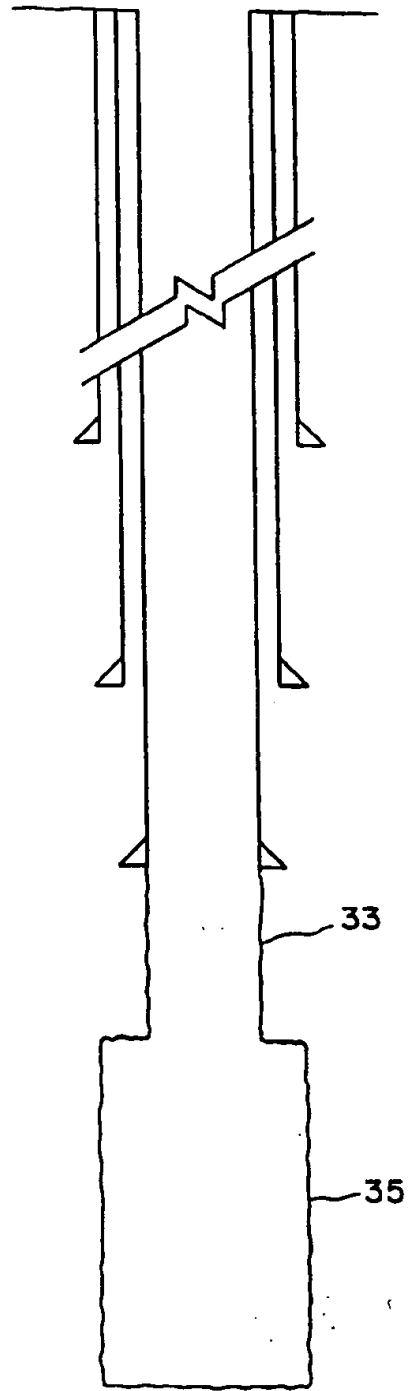

Fig. 12a



Continuation of Application No. 08/111,111

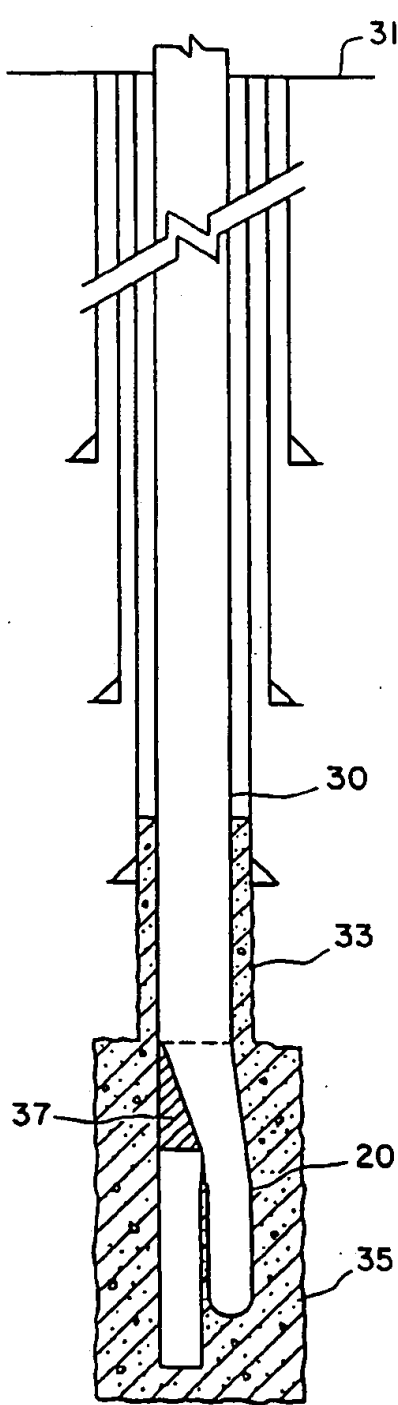

Fig. 12c

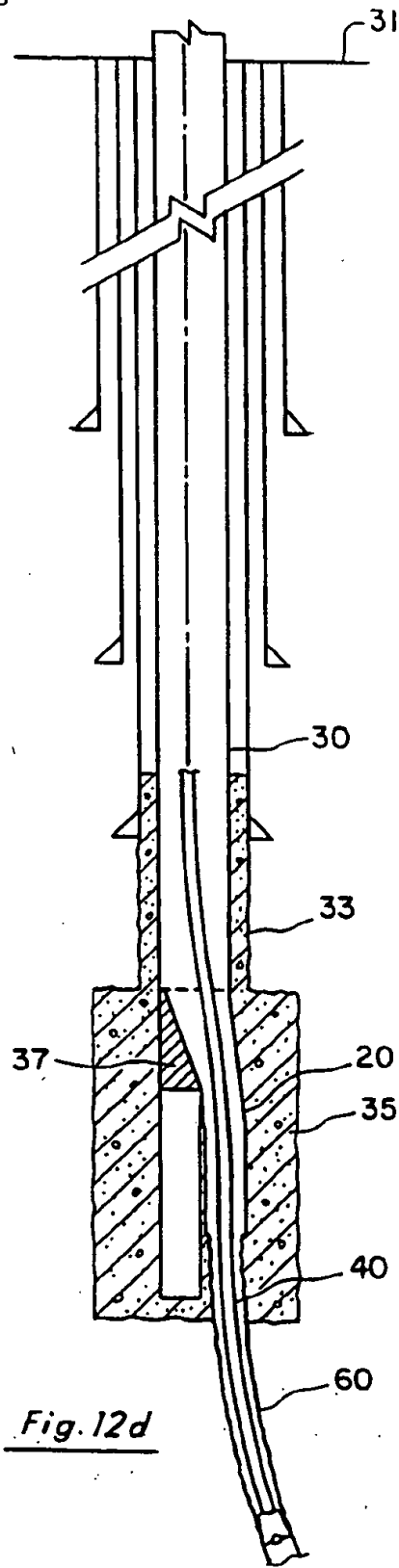
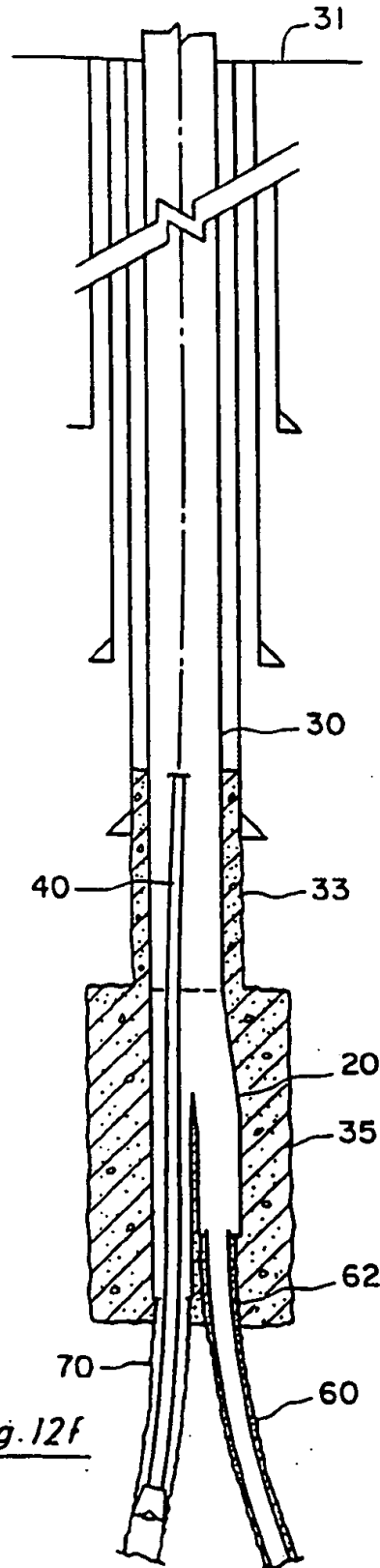
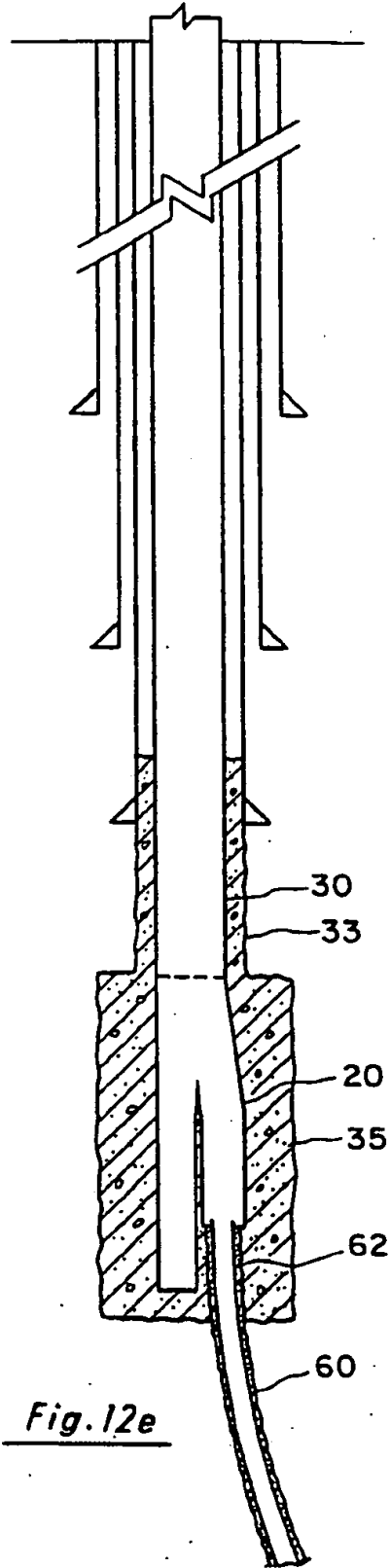

Fig. 12d



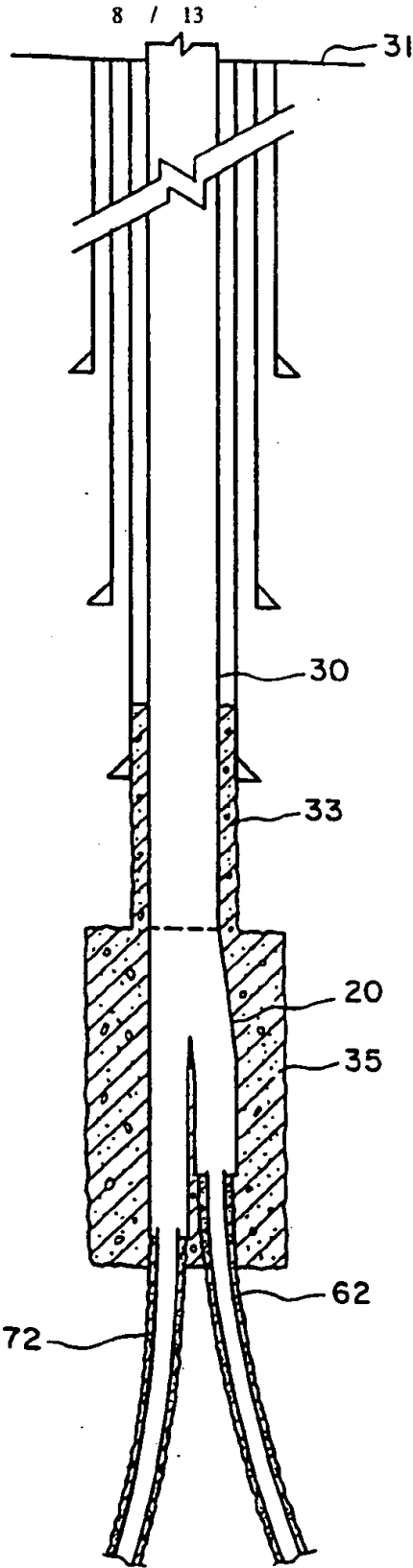

Fig. 12g



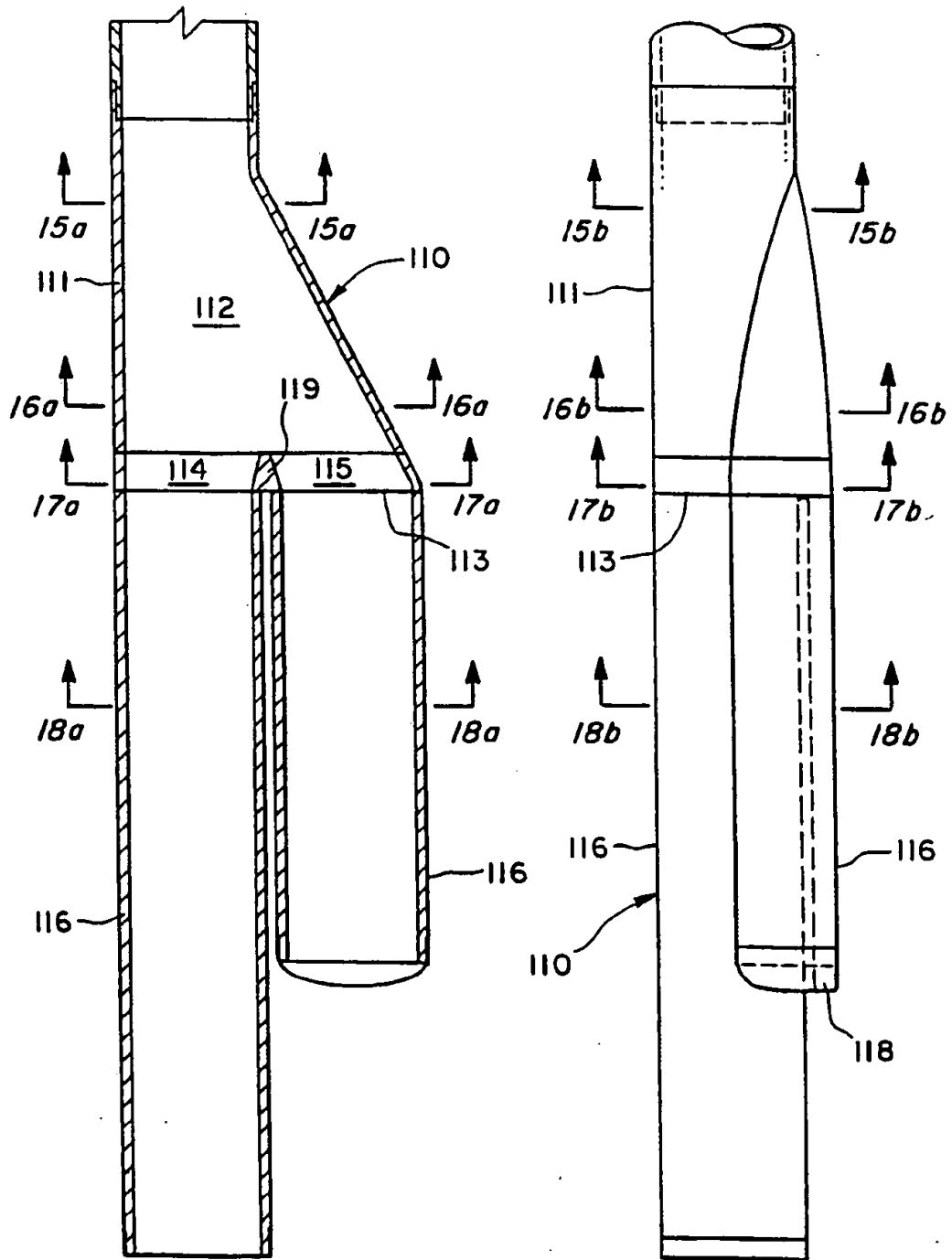

Fig. 13

Fig. 14

UNCLASSIFIED CONFIDENTIAL

Fig. 15a

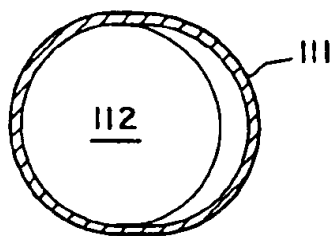

Fig. 15b

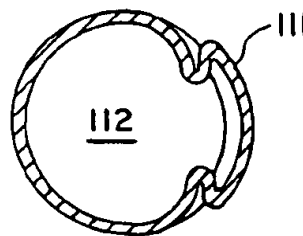

Fig. 16a

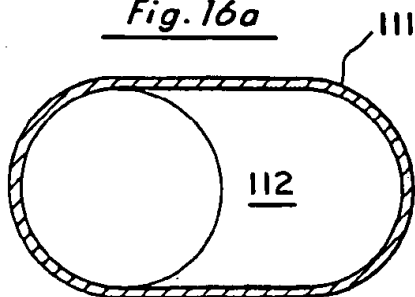

Fig. 16b

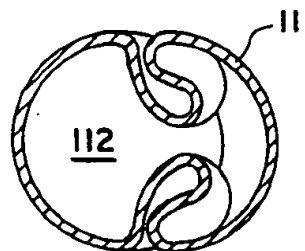

Fig. 17a

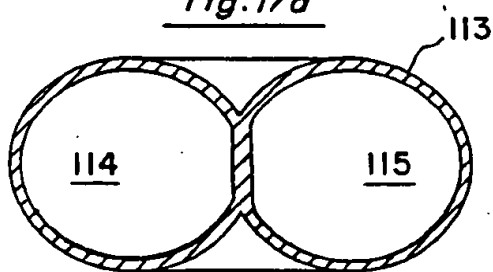

Fig. 17b

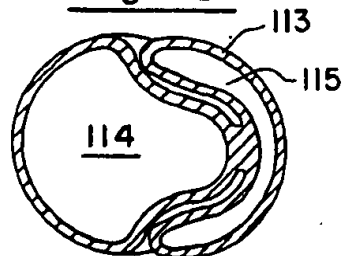

Fig. 18a

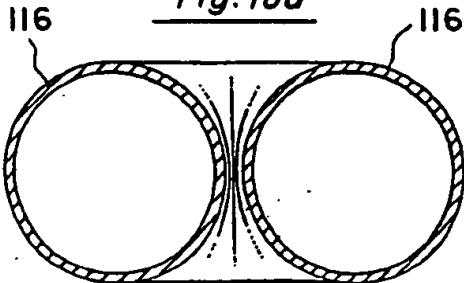

Fig. 18b

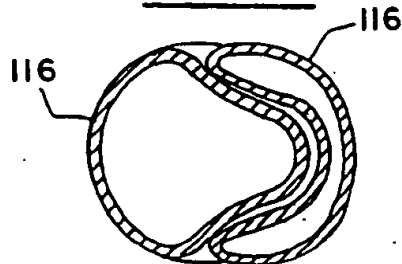

Fig. 19

Fig. 20

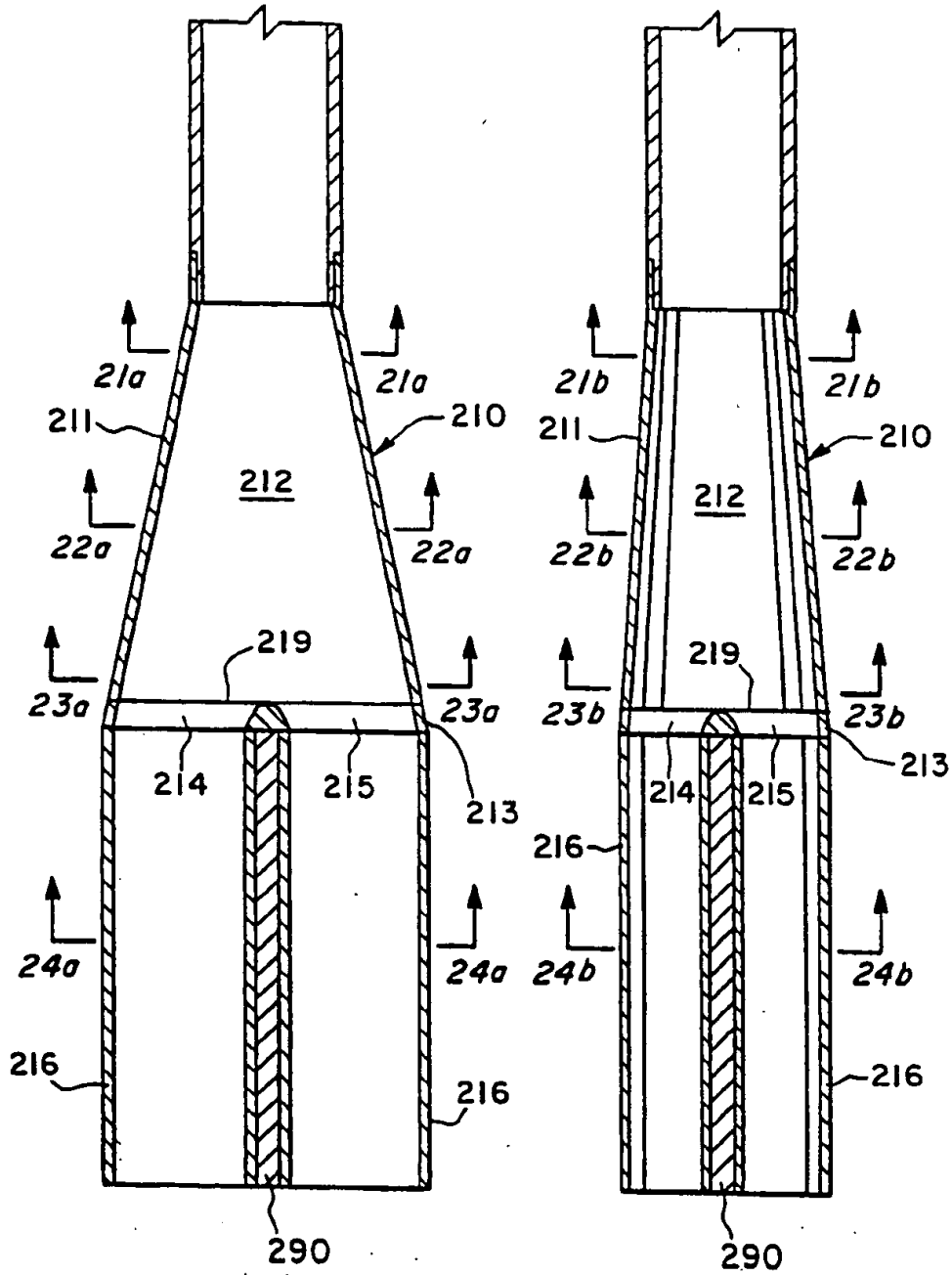

Fig. 21a

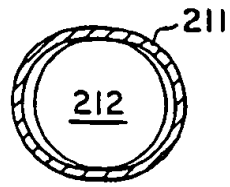

Fig. 21b

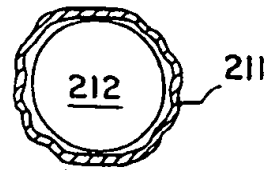

Fig. 22a

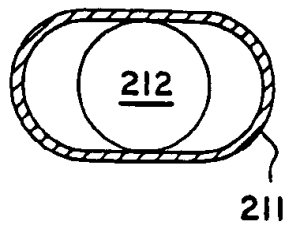

Fig. 22b

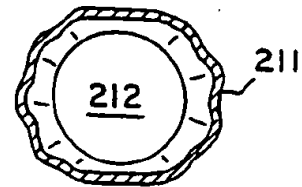

Fig. 23a

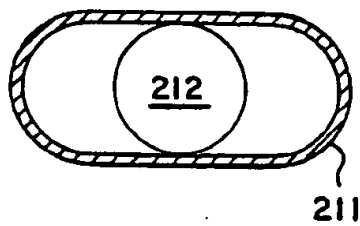

Fig. 23b

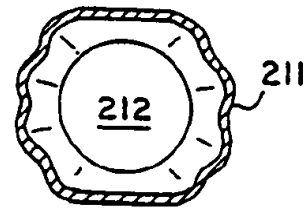

Fig. 24a

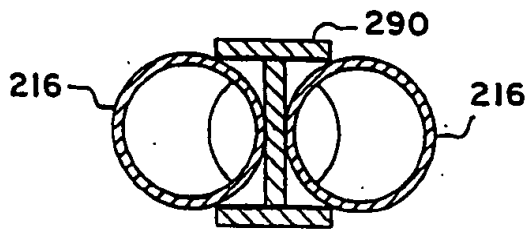

Fig. 24b

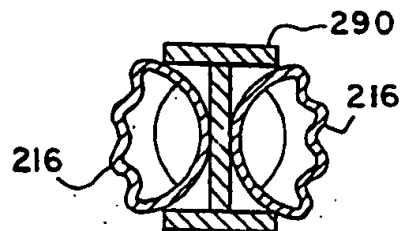

Fig. 25a

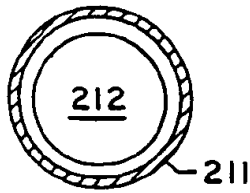

Fig. 25b

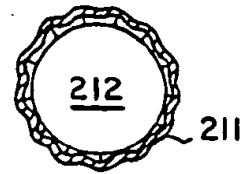

Fig. 26a

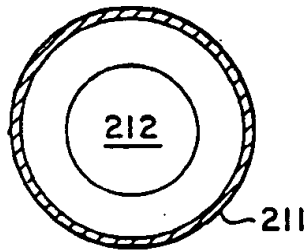

Fig. 26b

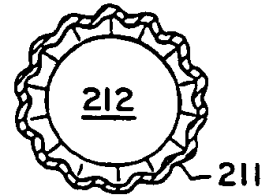

Fig. 27a

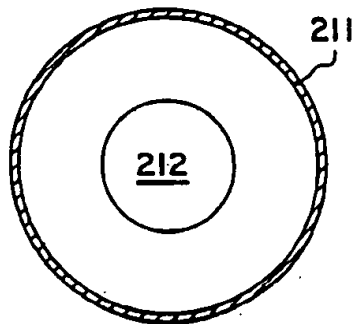

Fig. 27b

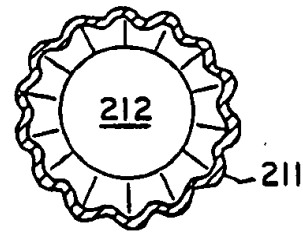

Fig. 28a

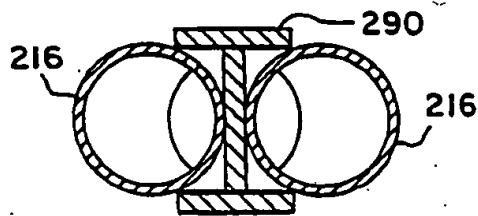
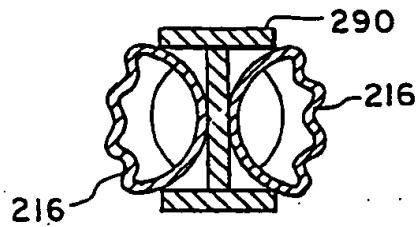

Fig. 28b



## INTERNATIONAL SEARCH REPORT

International application No.  
PCT/US98/04383

<b>A. CLASSIFICATION OF SUBJECT MATTER</b>		
IPC(6) :E21B 23/00 US CL :175/61; 166/207 According to International Patent Classification (IPC) or to both national classification and IPC		
<b>B. FIELDS SEARCHED</b>		
Minimum documentation searched (classification system followed by classification symbols) U.S. : 175/61,75,79; 166/207,117.5,242.3		
Documentation searched other than minimum documentation to the extent that such documents are included in the fields searched none		
Electronic data base consulted during the international search (name of data base and, where practicable, search terms used) none		
<b>C. DOCUMENTS CONSIDERED TO BE RELEVANT</b>		
Category*	Citation of document, with indication, where appropriate, of the relevant passages	Relevant to claim No.
A,E	US 5,732,773 A (PARKS ET AL) 31 March 1998 (31/03/98), see entire document.	1-47
A	US 3,489,220 A (KINLEY) 13 January 1970 (13/01/70), see entire document.	1-47
A	US 5,366,012 (LOHBECK) 22 November 1994 (22/11/94), see entire document.	1-47
<input type="checkbox"/> Further documents are listed in the continuation of Box C. <input type="checkbox"/> See patent family annex.		
<p>* Special categories of cited documents:</p> <p>*A* document defining the general state of the art which is not considered to be of particular relevance</p> <p>*E* earlier document published on or after the international filing date</p> <p>*L* document which may throw doubts on priority claim(s) or which is cited to establish the publication date of another citation or other special reason (as specified)</p> <p>*O* document referring to an oral disclosure, use, exhibition or other means</p> <p>*P* document published prior to the international filing date but later than the priority date claimed</p> <p>*T* later document published after the international filing date or priority date and not in conflict with the application but cited to understand the principle or theory underlying the invention</p> <p>*X* document of particular relevance; the claimed invention cannot be considered novel or cannot be considered to involve an inventive step when the document is taken alone</p> <p>*Y* document of particular relevance; the claimed invention cannot be considered to involve an inventive step when the document is combined with one or more other such documents, such combination being obvious to a person skilled in the art</p> <p>*A* document member of the same patent family</p>		
Date of the actual completion of the international search 19 MAY 1998		Date of mailing of the international search report 23 JUN 1998
Name and mailing address of the ISA/US Commissioner of Patents and Trademarks Box PCT Washington, D.C. 20231 Facsimile No. (703) 305-3230		Authorized officer <i>Diane Smith for</i> WILLIAM P. NEUDER Telephone No. (703) 308-2168